



The PRO-LHA is designed for use on small commercial rolling doors & grilles that require no more than 15 cycles per hour

STANDARD FEATURES

- 2 year Warranty
- **Control Circuit (2 options)**
- * **1- (M)** Heavy duty relays incorporating the new UL325 (2010) Interface Module.
 - *C2 factory wiring standard (constant pressure close), B2 wiring can be field set by moving 1 jumper and installing Micanan monitored fail safe photo-eyes (supplied) or (optional) Micanan compatible monitored fail safe electric edge
- 2-** Heavy duty relays (Not available in US or other areas where UL325 (2010) is mandated)
 - *C2 factory wiring standard (constant pressure close), B2 wiring can be field set by moving 1 jumper. Provisions for standard reversing devices.
- 24V class 2 control circuit with 40VA transformer to protect against short circuit
- External radio control terminal strip
- Low friction powder metal limit cam nuts with fully adjustable rotary type limit switch assembly
- Three button open-close-stop control station Nema-1
- 1/2 HP high starting torque, instant reversible motor protected by internal automatic thermal overload device
- Heavy duty 4L V-belt
- #41 roller chain & sprockets on all internal drives
- Adjustable friction clutch
- 3/4" permanently lubricated & sealed ball bearings on pulley shaft
- 1" permanently lubricated & sealed ball bearings on final drive shaft
- Mechanical brake system
- Solenoid brake (optional PRO-LHAB)
- Emergency chain hoist with electrical cut-out switch for manual operation
- Chain keeper
- Left or right hand mounting (must specify at time of order)
- #41 roller chain and sprockets on final drive
- Baked on dark grey coat finish
- Shipping weight 70 lbs



Commercial limited duty belt drive jackshaft operator with emergency chain hoist for sheet doors

When ordering a PRO-LHA operator, supply Micanan with the following information

- Door height
- Door width
- Type of door
- Voltage/hase
- Safety devices
- Door shaft diameter & door shaft key size
- Mounting (LH or RH, Bracket or Wall mount)
- Options

MECHANICAL DIMENSIONS

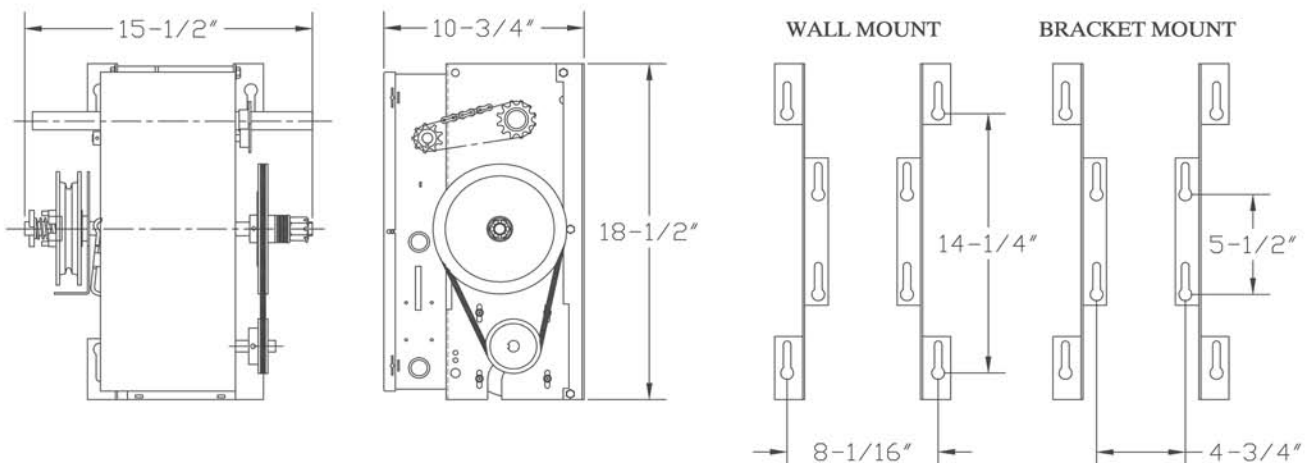

FOR MORE INFORMATION, PLEASE VISIT WWW.MICANAN.COM OR CONTACT US AT