

600 SERIES ROLLING GRILLES

DURABLE ROLLING GRILLES WITH MULTIPLE BENEFITS

Wayne Dalton Rolling Grilles offer total security, visibility, and ventilation in a number of patterns and finishes for commercial, industrial, retail, and institutional applications. These grilles are available in steel, aluminum, or stainless steel to meet any need.



- SIZES UP TO 42' WIDE AND 26' HIGH
- VARIETY OF PATTERNS AND MATERIALS
- EXTREMELY DURABLE CONSTRUCTION

ROLLING GRILLES 600 SERIES

Wayne Dalton Rolling Grilles are designed to maximize security, visibility, and ventilation. The durable construction technique used ensures that the grilles will offer many years of reliable and consistent performance.

Materials & Construction

Standard features include 5/16" galvanized steel horizontal rods, continuous from jamb to jamb, and covered with aluminum tubes. Vertical links are aluminum. End links ensure that the grille cannot be pulled from guides.

The bottom bar is a tubular aluminum extrusion, fitted with nylon end caps which act as bearing surfaces.

Optional cylinder lock assembly in bottom bar activates concealed 3/8" steel tamperproof lock rods. Lock uses standard mortise cylinder, and is also available with an optional removable core. Center locks available up to 25' wide.

Aluminum grill patterns are available in clear, mill, or bronze anodized finishes. Optional materials are #304 finished stainless steel and galvanized steel.

Powder coating is available in 180 colors. Powder coating is a dry finishing process in which finely ground particles of pigment and resin are electrostatically charged and sprayed onto the electrically grounded parts of rolling doors. These charged particles adhere to the rolling door parts until they melt and fuse into a solid coating in a curing oven. The result is a finish that radiates beauty and smoothness for an aesthetically pleasing grille.

Operation can be manual push-up, chain, crank, or motor-operated. Door mounting can be self-supporting, using structural tubes, or directly to the building structure.

Counterbalance assembly consists of a spring barrel which serves as a load-carrying beam. It encases the counterbalance mechanism and provides the axis around which the curtain coils. (Deflection is limited to 0.033" per lineal foot of span.) If required, barrel rings of malleable iron or stamped steel may be provided to assure proper countebalance. Oil-tempered, torsion-type counterbalance springs are wound from heat-treated steel, providing accuracy in balancing the door. Barrel plugs connect ends of springs to barrel and tension rod. Tension rod of steel shafting holds fixed ends of springs and carries torsional load of spring counterbalance.

Spring tension adjusting wheel is normally mounted outside the bracket on end of tension rod. Inside adjusting wheel for tight side-room applications is available in limited sizes.

Optional hood cover encloses curtain coil and counterbalance mechanism and is made to match the grille finish.



Available patterns

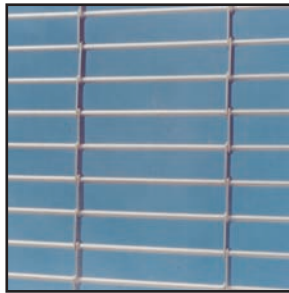

G6 Pattern (standard)
For aluminum, galvanized and stainless steel.

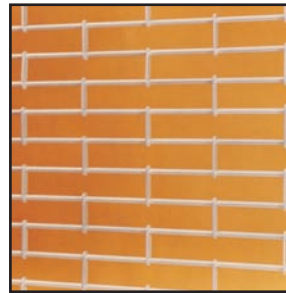

G1 Pattern (optional)
For aluminum, galvanized and stainless steel.

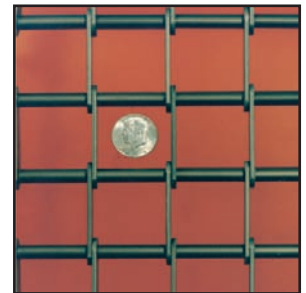

G7 Pattern (optional)
Designed with closer spacing of vertical links (2"). Shown in bronze anodized aluminum. Note: dime shown for scale.

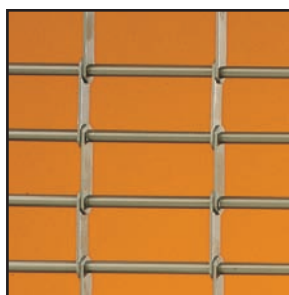

G8 Pattern (optional)
Designed with closer spacing of vertical links, but wider than G7 pattern.

Options

- Steel Mounting Tubes
- Lexalite Inserts
- Centerlock Security Pattern
- Sloped Bottom Bars
- Drop Stop Device
- Safety Edges
- Powder Coating
- Cable Releases
- Super-Imposed Combination Doors
- Multiple Locking Combinations
- Emergency egress available on motor operated doors

ROLLING GRILLES 600 SERIES

MANUAL OPERATION

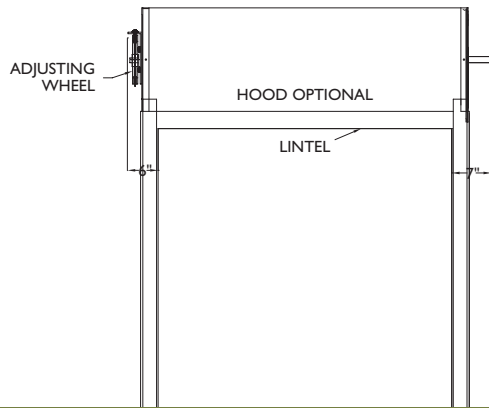

ELEVATION

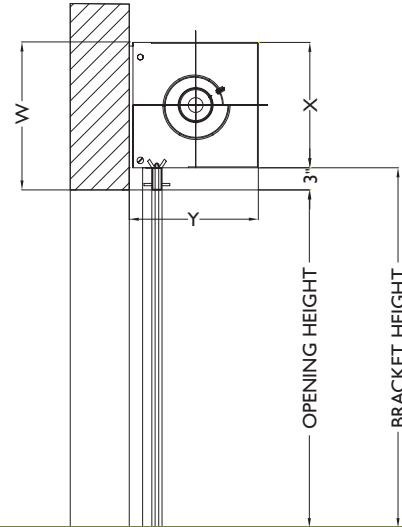

SECTION

CHAIN HOIST OPERATION

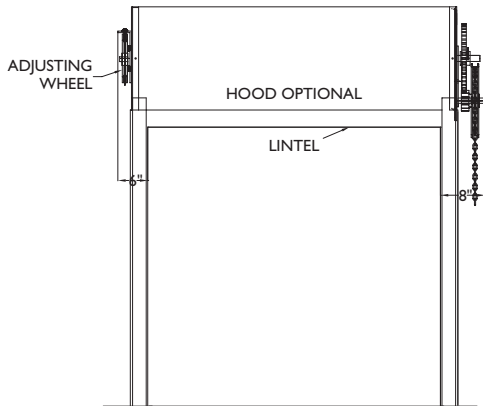

ELEVATION

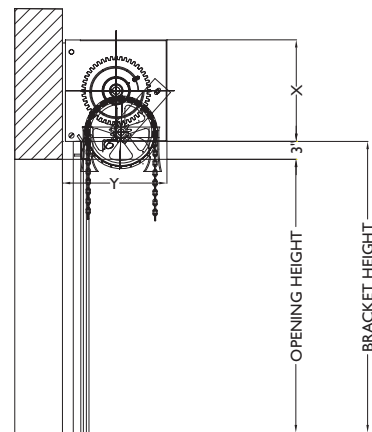

SECTION (FACE MOUNTED)

BETWEEN JAMBS

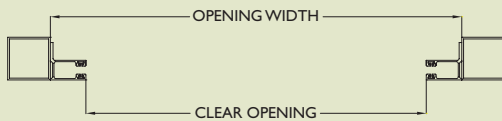

BETWEEN JAMBS WITH PACK OUT ANGLES

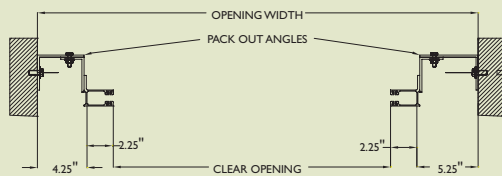

FACE MOUNTED



ROLLING GRILLES 600 SERIES

AWNING CRANK OPERATION

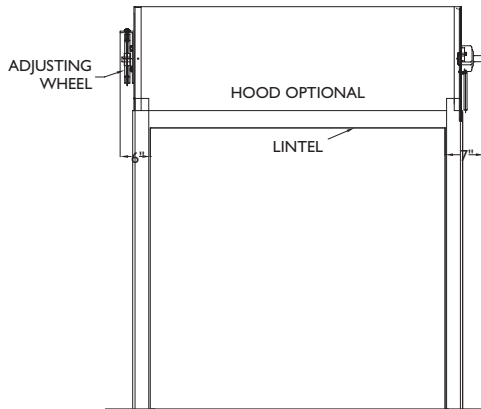

ELEVATION

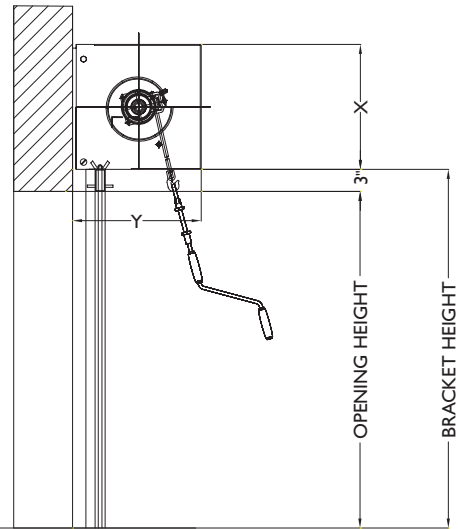

SECTION (FACE MOUNTED)

MOTOR OPERATION

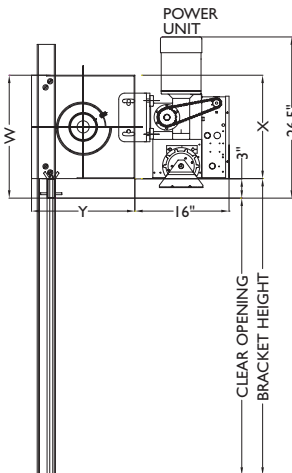

SECTION (BETWEEN JAMBS)

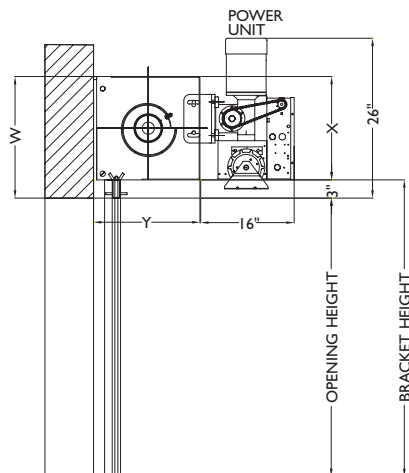

SECTION (FACE MOUNTED)

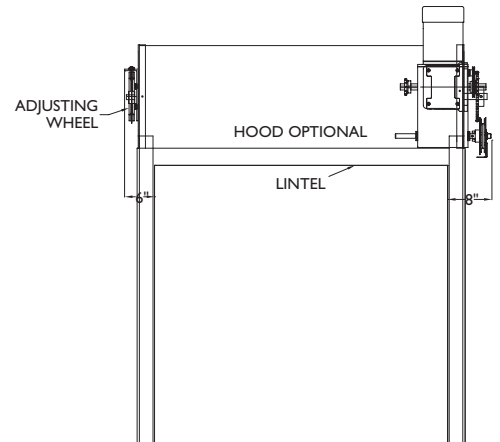

ELEVATION (POWER UNIT)



ROLLING GRILLES 600 SERIES

Aluminum Grilles

WIDTH	HEIGHT	BRACKET SIZE	X	Y	W	R	L
30'	6'0"	14"	14"	14-1/2"	17"	SEE SKETCH	SEE SKETCH
30'	7'1"	15"	15"	15-1/2"	18"	SEE SKETCH	SEE SKETCH
30'	7'11"	16"	16"	16-1/2"	19"	SEE SKETCH	SEE SKETCH
30'	10'4"	17"	17"	17-1/2"	20"	SEE SKETCH	SEE SKETCH
30'	12'0"	18"	18"	18-1/2"	21"	SEE SKETCH	SEE SKETCH
30'	14'6"	19"	19"	19-1/2"	22"	SEE SKETCH	SEE SKETCH
25'	18'0"	20"	20"	20-1/2"	23"	SEE SKETCH	SEE SKETCH
30'	17'2"	20"	20"	20-1/2"	23"	SEE SKETCH	SEE SKETCH
25'	20'0"	21"	21"	21-1/2"	24"	SEE SKETCH	SEE SKETCH
30'	18'0"	21"	21"	21-1/2"	24"	SEE SKETCH	SEE SKETCH
30'	20'0"	23"	23"	23-1/2"	26"	SEE SKETCH	SEE SKETCH

Steel Grilles and Stainless Steel Grilles

WIDTH	HEIGHT	BRACKET SIZE	X	Y	W	R	L
30'	7'0"	16"	16"	16-1/2"	19"	SEE SKETCH	SEE SKETCH
30'	10'0"	17"	17"	17-1/2"	20"	SEE SKETCH	SEE SKETCH
30'	7'11"	16"	16"	16-1/2"	19"	SEE SKETCH	SEE SKETCH
30'	12'0"	18"	18"	18-1/2"	21"	SEE SKETCH	SEE SKETCH
26'	15'0"	19"	19"	19-1/2"	22"	SEE SKETCH	SEE SKETCH
30'	14'0"	19"	19"	19-1/2"	22"	SEE SKETCH	SEE SKETCH
28'	18'0"	20"	20"	20-1/2"	23"	SEE SKETCH	SEE SKETCH
30'	17'0"	20"	20"	20-1/2"	23"	SEE SKETCH	SEE SKETCH
16'	20'0"	21"	21"	21-1/2"	24"	SEE SKETCH	SEE SKETCH
25' TO 30'	18'0"	21"	21"	21-1/2"	24"	SEE SKETCH	SEE SKETCH
30'	20'0"	23"	23"	23-1/2"	26"	SEE SKETCH	SEE SKETCH

NOTE: Dimensions are for general reference only and not for construction purposes.



ROLLING GRILLES 600 SERIES

Note to specifiers: Words in brackets indicate frequently specified and highly recommended options.

PART I – GENERAL

1.01 Work Included

- A. The opening will be equipped with Wayne Dalton 600 Series rolling grilles.

1.02 Related Work

- A. Opening preparation, miscellaneous or structural metal work, access panels, finish or field painting, field electrical wiring, wire, conduit, fuses, and disconnect switches are in the Scope of Work of other divisions or trades.

1.03 Reference Standards

- A. **ANSI/DASMA203** – American National Standards Institute Specifications for non-rated fire rolling doors published by Door & Access Systems Manufacturers Association International.
- B. **ASTM A123** – Zinc [hot-dipped galvanized] coatings on iron and steel products.
- C. **ASTM A229** – Steel wire, oil-tempered for mechanical springs.
- D. **ASTM A-653-94** – Steel sheet, zinc-coated [galvanized] by the hot-dipped process, commercial quality.

1.04 Quality Assurance

- A. Rolling grilles and all accessories and components required for complete and secure installations shall be manufactured as a system from one manufacturer.

1.05 Systems Description

- A. Rolling Grille: Type: **Model 600**
- B. Mounting: [steel] [wood] [masonry] jambs
- C. Operation: [manual push-up] [crank] [chain hoist] [motor] [motor with chain hoist]
- D. Material: [Galvanized steel] [aluminum] [stainless steel]

1.06 Submittals

- A. Shop Drawings: Clearly indicate the following:
 - 1. All details required for complete operation and installation.
 - 2. Hardware locations.
 - 3. Type of metal and finish for door sections.
 - 4. Finish for miscellaneous components and accessories.
- B. Product Data: Indicating manufacturer's product data, and installation instructions.

1.07 Delivery, Handling, Storage

- A. Deliver products in manufacturer's original containers, dry, undamaged, seals and labels intact.
- B. Store and protect products in accordance with manufacturer's recommendations.

1.08 Warranty

- A. Standard manufacturer's one year warranty against defects in material and workmanship.

PART II – PRODUCTS

2.01 Curtain

- A. Curtains are to be fabricated of 5/16" galvanized steel horizontal rods, continuous from jamb to jamb, covered with aluminum tubes. Vertical links and tubes available in stainless, aluminum or galvanized steel. End links insure that grille cannot be pulled from guides.

2.02 Guides

- A. Guides will be of extruded aluminum with wool pile inserts to contact both faces of grille, acting as wearing surfaces and sound deadener.

2.03 Brackets

- A. Bracket Plates will be of 3/16" minimum [1/4"] steel plate. Sealed ball bearings to support the counterbalance assembly. Brackets to form end closures and support hoods.

2.04 Counterbalance

- A. Curtain to be coiled on a pipe of sufficient size to carry door load with deflection not to exceed .033" per foot of door span and to be correctly balanced by helical springs, oil tempered torsion type. Cast iron barrel plugs will be used to anchor springs to tension shaft and pipe.

2.05 Hood

- A. When required, hood is to be fabricated of 24-gauge galvanized steel (stainless steel) (20 B&S gauge aluminum). Provide intermediate hood supports over 16'0" opening width.

2.06 Finish

- Finish for aluminum surfaces is to be (mill) (clear anodized 204R I) (bronze anodized). Non-galvanized steel surfaces are to be painted one shop coat of rust inhibiting primer. Stainless steel to be #304 brushed.

2.07 Operation

- A. Grilles will be operated by means of (manual, with lift handles) (by chain and gear—maximum pull of 35 lbs.) (by fully enclosed awning type crank gearing and removable crank arm) (by motor operator).

2.08 Locking

- A. Manual or crank operated grilles to be by means of slide bolt locking device operable from inside or outside. Chain lock keeper on chain operated doors. Motor operated grilles to include self-locking gearing plus chain locking device for emergency chain.

Note: When specifying locks on electric-motor operated doors, electric interlocks should also be specified to prevent operation when lock bolts are engaged in the guides, thus preventing damage to the curtain and/or operator.

PART III – EXECUTION

3.01 Installation

- A. General:
 - 1. Install grilles in accordance with manufacturer's instructions and standards. Installation shall be by an authorized Wayne Dalton representative.
 - 2. Verify that existing conditions are ready to receive rolling grille work.
 - 3. Beginning of rolling grille work means acceptance of existing conditions.
- B. Install grille complete with necessary hardware, jamb and head mold strips, anchors, inserts, hangers, and equipment supports in accordance with final shop drawings, manufacturer's instructions, and as specified herein.
- C. Fit, align and adjust rolling grille assemblies level and plumb for smooth operation.
- D. Upon completion of final installation, lubricate, test and adjust grilles to operate easily, free from warp, twist or distortion and fitting for entire perimeter.

Note: Architect may consider providing a schedule when more than one rolling grille or opening type is required.



Distributed By:



For technical information, visit:
www.Wayne-Dalton.com/commercial